

PIVOTING JET CLEANERS

TO CLEAN STORM TANKS





Problem.

In the storm tanks, especially in CSO systems, sludge and mud are settled to the bottom of the tank.

Despite many efforts made to optimize the storm tanks design and minimize maintenance, practice shows that is not possible to get a self-cleaning design for the tank by itself.

To avoid healthy and odour related problems due to the accumulation of sediments, the Water Company must do a regular cleaning of the tank. Personal costs and healthy risks associated are the reasons why storm tanks are equipped with automatic cleaning systems.

Pivoting jet cleaners applications.

Pivoting jet cleaners are one of the alternatives to make the automatic cleaning of the storm tanks. They can be installed in new or existing tanks, independently of their geometry (rectangular tanks, circular tanks,...).

Pivoting jet cleaners have been tested in deposits with a long return time, where the oxygen addition to the waste water is necessary.



Fig. 1. Sedimentation in storm tank.



Pivoting jet cleaners operation.

Pivoting jet cleaner consists of a waste water submersible pump equipped with a jet that is assembled to an actuator to allow rotation of it.

Air is introduced and added in the water stream, and this mixture of water and air is propelled horizontally over the bottom of the tank with very high speed.

Combination of water and air stream causes this high speed, that keeps the water volume in rotation, so the sludge is keep on suspension and sediments are mixed again and keep on suspension as the water height is reduced in the storm tank.

In long tanks with bad floor designs, tanks with very little slope in two directions, and in tanks with intermediate pillars, the cleaning with a stationary jet could be very difficult, because the stream can't reach all the places during emptying period of the tank.

In that places will be permanent sedimentation, and it will increase during the rain events, even it's possible to appear vegetation in some open storm tanks.

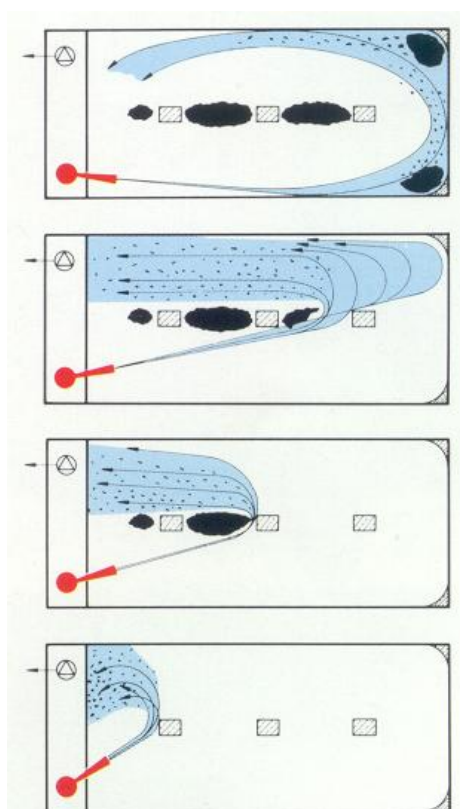

Fig. 2. Operation principle.

The pivoting jet cleaner works as a stationary unit until emptying of the tank starts and maintains the water volume in rotation. Pivoting jet cleaner turns very slowly to right and left to reach all of the corners.



This way of operation guarantees that during the last emptying stage of the tank, all the zones of the bottom of the tank are directly cleaned.

Design of pivoting jet cleaners.

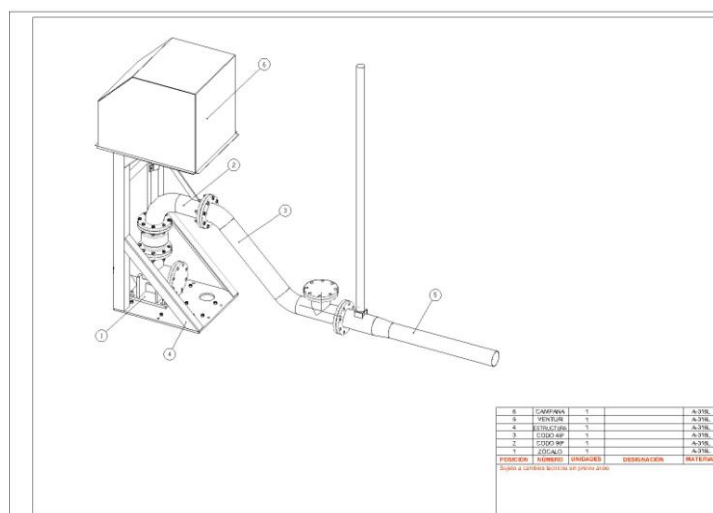

Fig. 3. Design of pivoting jet cleaner with diving bell.

Pivoting jet cleaner is a compact unit; consist of a waste water submersible pump and a multi-turn actuator. The system is fixed to the floor, and allows the turn of the jet by an articulation.

The water is collected from a well or the outlet canal of the tank. Maximum installation depth is 5 meters. Actuator can't be submerged, and must be installed in the highest over the top water level or inside a diving bell, see figure 3.

It's recommended to install a registry cover over the pivoting jet cleaner to allow extraction and maintenance operations of the pumps in case of necessary.



Fig. 4. Pivoting jet cleaners running.



Installation.

Figure 5 shows typical installation of pivoting jet cleaner in a rectangular tank.

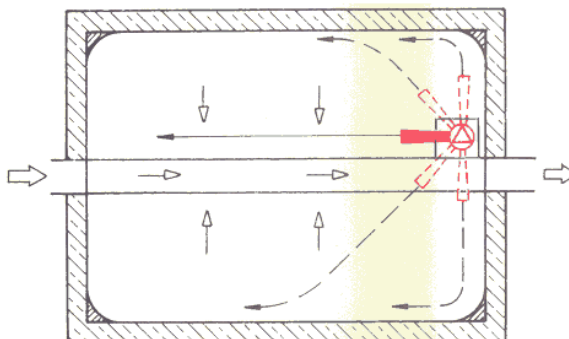

Fig. 5. Pivoting jet cleaner in a rectangular tank.

For circular tanks, the optimal installation is in the outlet face, making the operation of the system more efficient.

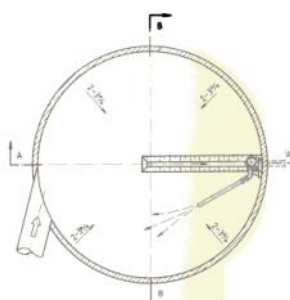

Fig. 6. Pivoting jet cleaner in a circular tank.



Technical data.

Power (Kw)	Current (A)	Flow (m ³ /h)	Rectangular tanks up to	Circular tanks up to
6,0	12,9	250	1-2x(10x20 m)	Diámetro 18 m
11,0	23,0	350	1-2x(12x24 m)	Diámetro 25 m
15,0	31,8	400	1-2x(14x26 m)	Diámetro 30 m

The power is approximate. For other dimensions, please consult us.



Fig. 7. Pivoting jet cleaner stopped.



Fig. 8. Pivoting jet cleaner running.

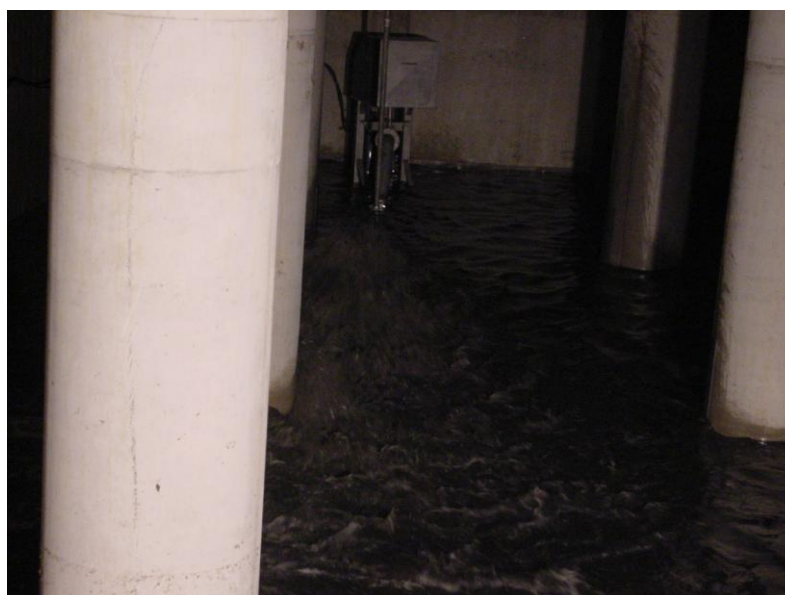

Fig. 9. Pivoting jet cleaner running.